

0,8/ 3,2/  
(▽) (▽)

Tolerance rozměrů	
XX	ISO 2768-mK
XX,X	± 0,1
XX,XX	± 0,01
XX,XXX	± 0,005

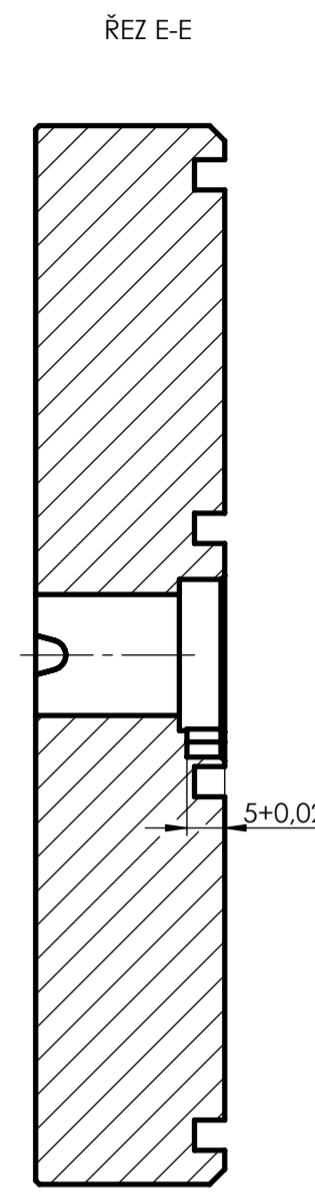

DETAIL D  
MĚŘÍTKO 3 : 1

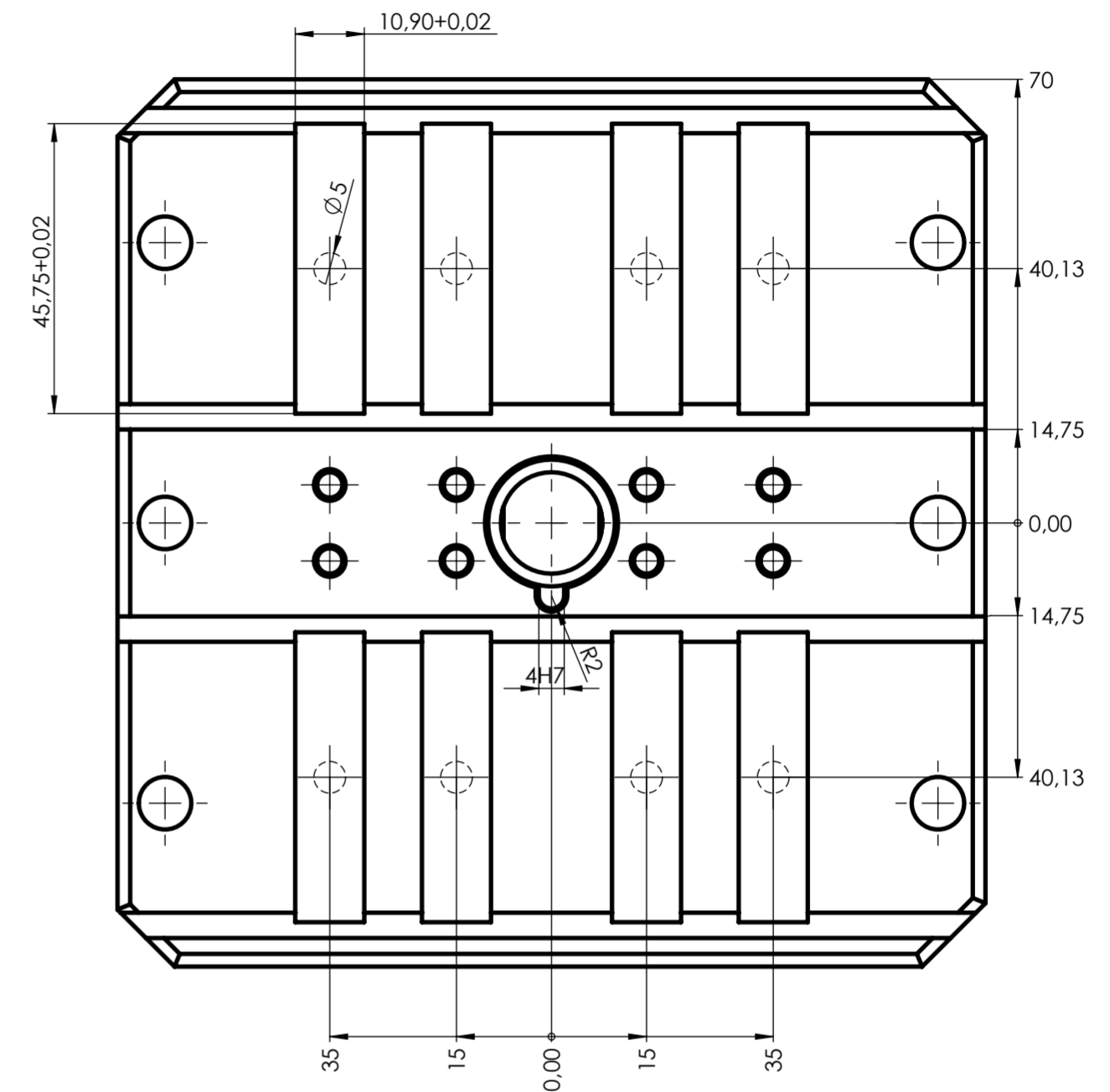
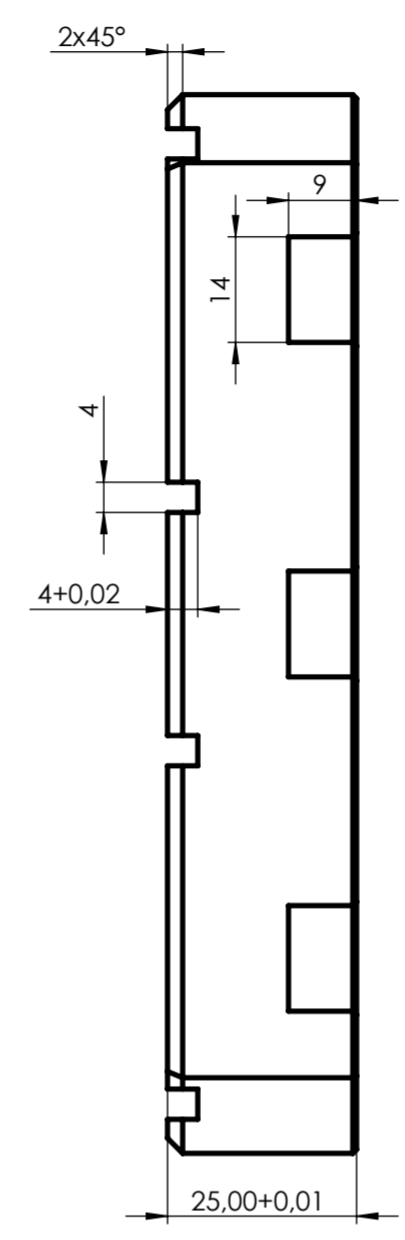
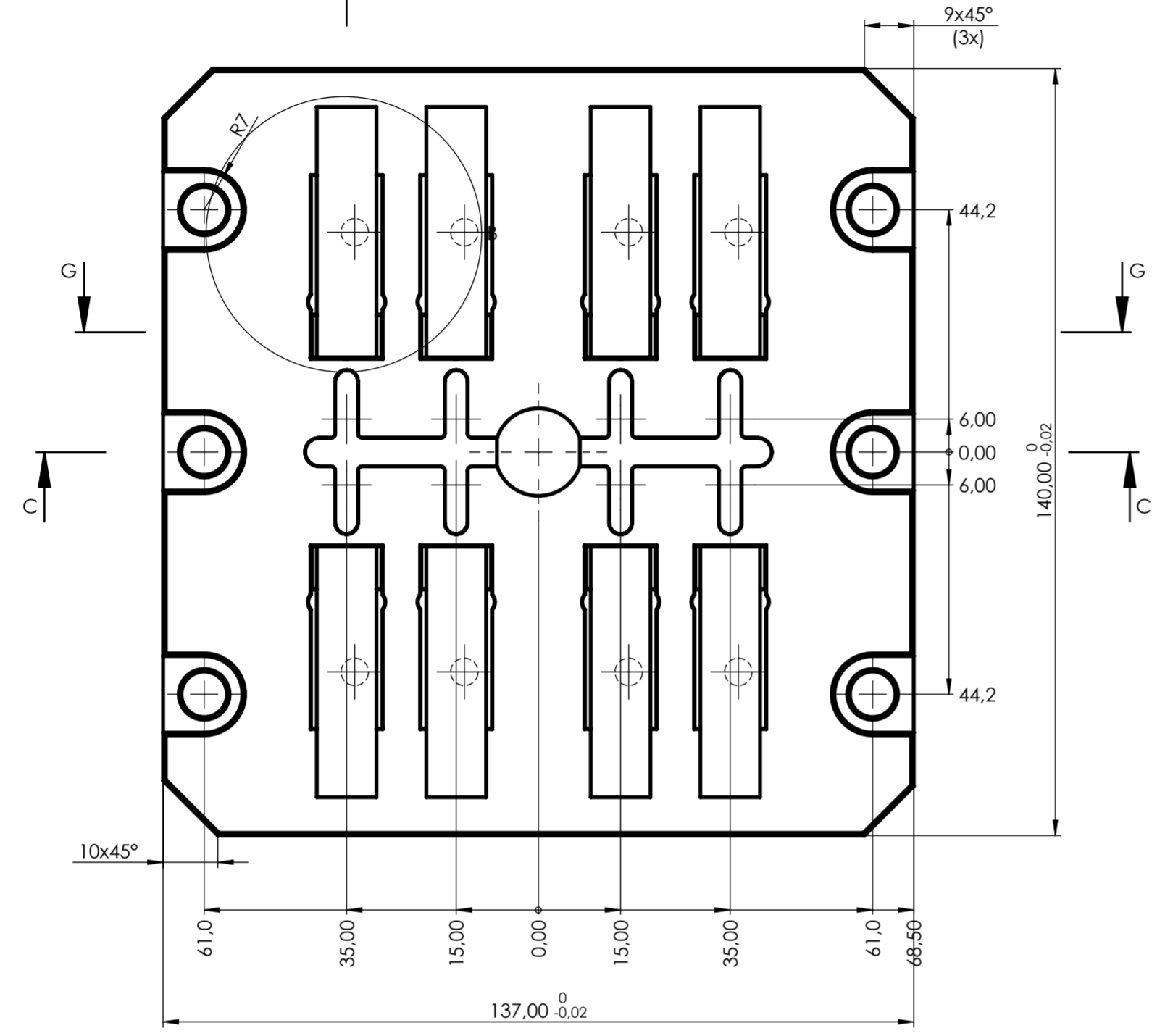
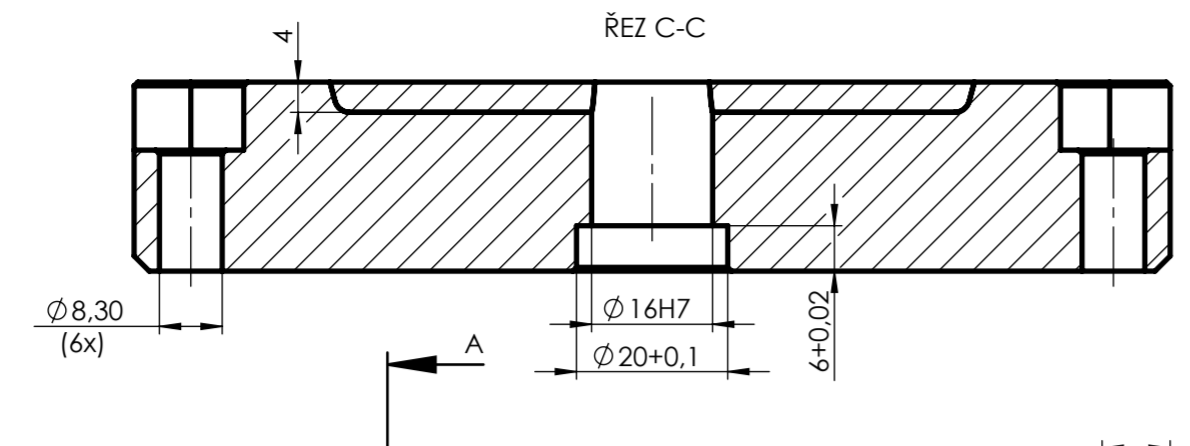
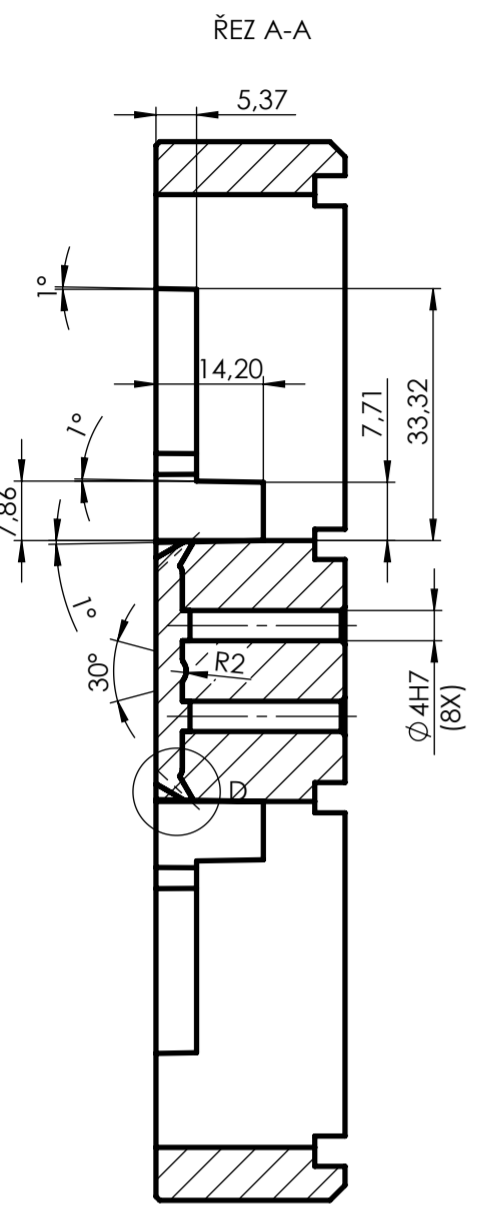
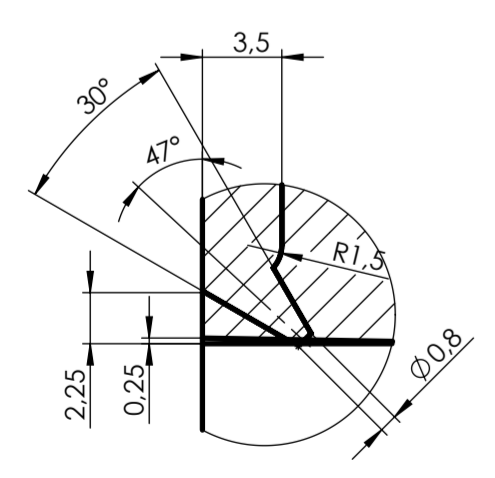

DETAIL B  
MĚŘÍTKO 2 : 1

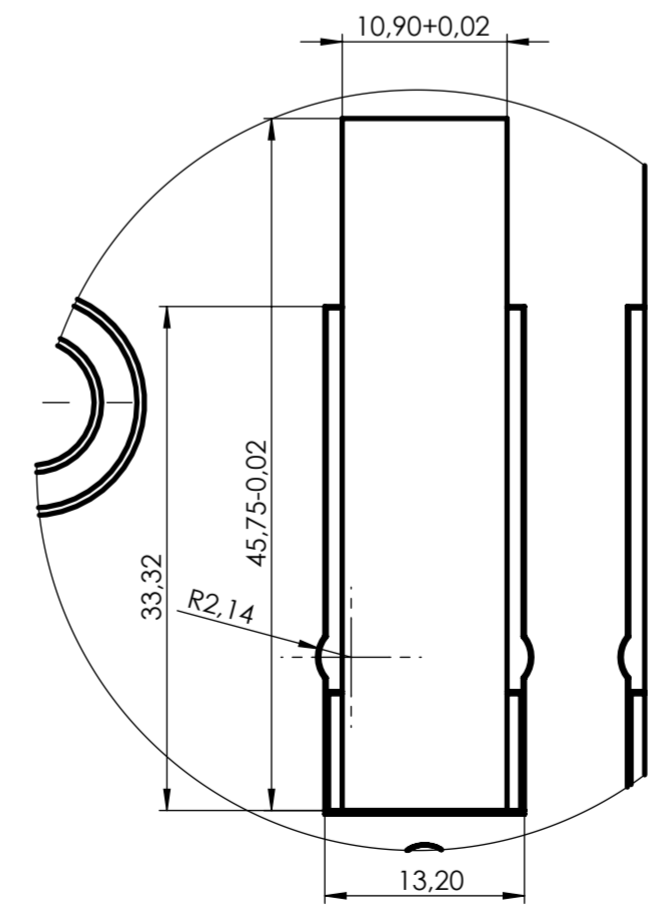

ŘEZ G-G

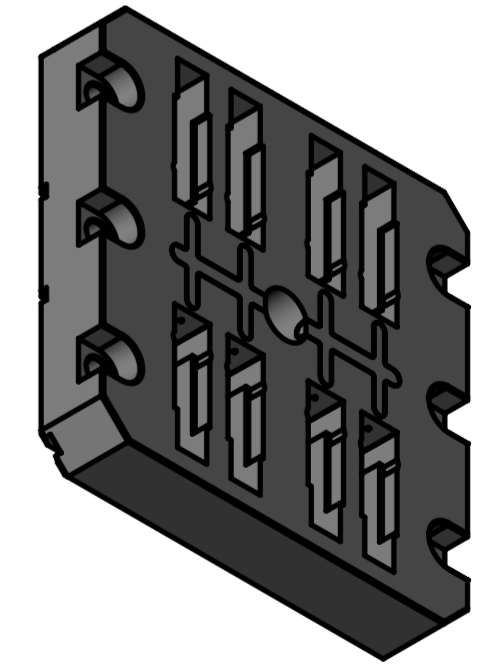
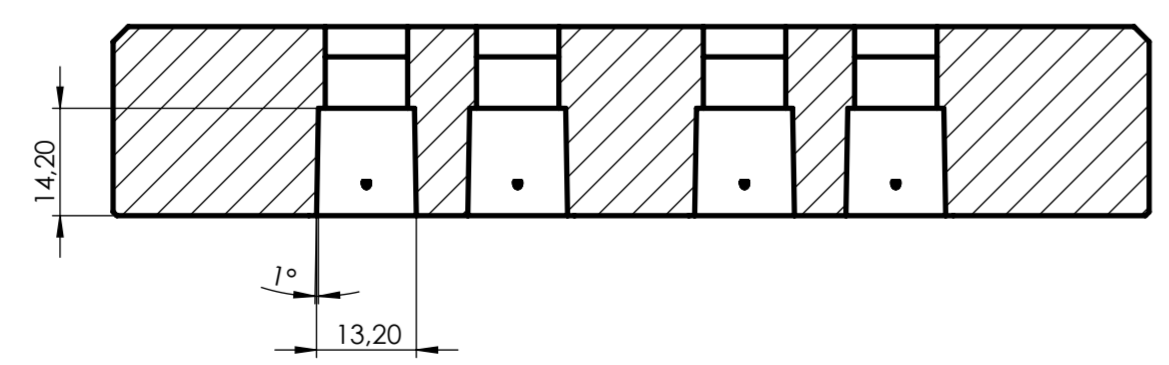

NEKOTOVANE TVARY DLE 3D DAT  
NEFUKNČNÍ HRANY OBJEHLIT  
NEKOTOVANA SRAZENÍ 0,5x45°

NÁZEV:	TVARNICE	MATERIÁL:	1.2343	POLOTOVAR:	145 x 142 x 32
POČET KUSŮ:	1	NORMA:		KALENO NA:	48+2Hrc
ROZMĚR	140 x 137 x 25	HMOTNOST:		POZICE:	013
MĚŘÍTKO	MODELOVAL:	PEŠL	PŘESNOST:	ISO 2768 mK	
1:1	KRESLIL:	PEŠL	PROVĚŘENÍ:		
	DATUM:	20.10.2017			
KRESLENO V SOLIDWORKS			A2		
ZÁKAZNÍK			autor      změna      verze		
UTB FT ZLÍN			č. VÝKRESU		
			LRS-71-215-013		
			LIST		
			1 z 1		